

Tools & Material Required

- PTFE tape
- Allen key - 12mm
- Spanner - 22mm
- Adjustable Spanner

Key	Component	Qty
A	Manual Body (flow)	1
B	Manual Body (return)	1
C	Nut	2
D	Valve Tail (1/2" BSP)	2
E	Compression Fitting (15mm)	2

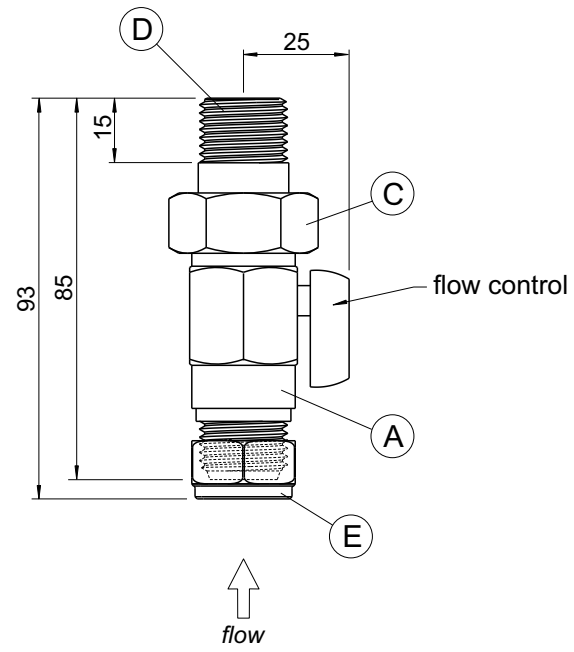
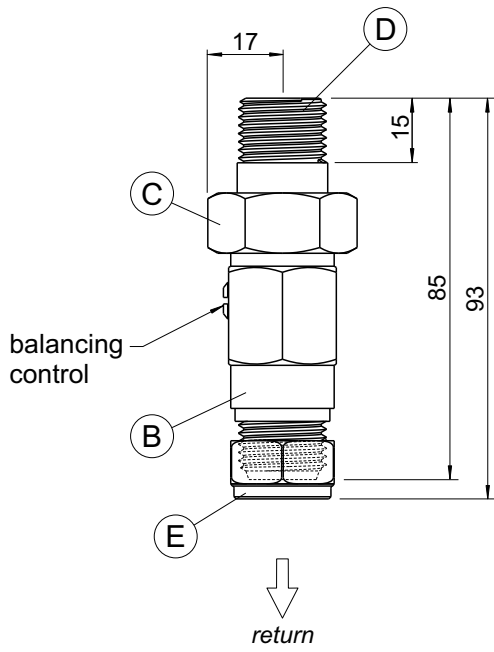

Assembly Instructions

Apply sufficient PTFE tape to valve tail threads (D), ensuring that tape is wound in a clockwise direction.

Fit valve tails (D) to radiator using 12mm Allen key, ensuring nut (C) is in place.

Note: over-tightening of valve tails may cause damage to surface finish of radiator connections.

Do not use grips.

Loosen compression fittings (E) and apply valve bodies (A) & (B) to 15mm pipe tails.

Install radiator onto bracket mountings and tighten valve tails (D) onto valve bodies (A) & (B).

Tighten compression fittings (E).

After filling and venting radiator, adjust balancing control to balance radiator.

Further technical information regarding valves (sheet TDS3.1) can be found on our website at www.bisque.co.uk or by calling and requesting a faxed or posted copy on **01225 478500** (Bath) or **0207 328 2225** (London).