

Tools & Material Required

Allen key - 12mm
Adjustable Spanner

| Key | Component | Qty |
|-----|----------------------------|-----|
| A | Thermostatic Cap | 1 |
| B | Thermostatic Body | 1 |
| C | Manual Body | 1 |
| D | Nut | 2 |
| E | Valve Tail (1/2" BSP) | 1 |
| F | Valve Tail (1/2" BSP) | 1 |
| G | Compression Fitting (15mm) | 2 |
| H | Isolating Cap | 1 |

Temperature Settings

★ Anti-Frost Setting
1 to 6 Approx. Range 12°C to 30°C

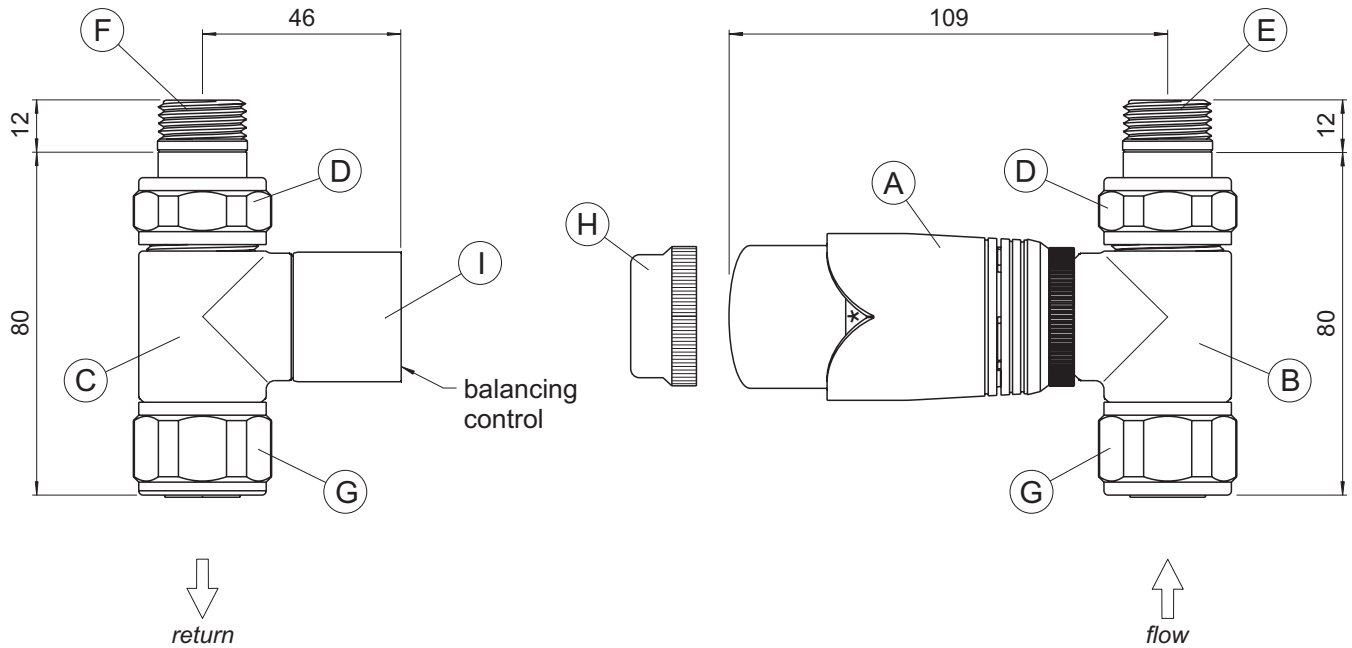

Assembly Instructions

Leave isolating cap (H) tightened to thermostatic body (B).

Fit valve tail (E) to flow side of radiator using 12mm Allen key, ensuring nut (D) is in place.
Note: over-tightening of valve tails may cause damage to surface finish of radiator connections. Do not use grips.

Fit valve tail (F) to return side of radiator using 12mm Allen key, ensuring nut (D) is in place.

Loosen compression fittings (G) and apply valve bodies (B) & (C) to 15mm pipe tails.

Install radiator onto bracket mountings and tighten valve tails (E) & (F) onto valve bodies (B) & (C) respectively.

Fully tighten compression fittings (G).

Remove isolating cap (H). *Note: retain cap for use during any future maintenance.*

Set reading on thermostatic cap (A) to '6' and tighten cap fully onto the thermostatic body (B).

After filling and venting radiator, remove cap (I) and adjust balancing control to balance radiator.

Please note: thermostatic valve must only be installed on the flow side of system.

Further technical information regarding valves (sheet TDS3.1) can be found on our website at www.bisque.co.uk or by calling and requesting a faxed or posted copy on **01225 478500** (Bath) or **0207 328 2225** (London).