



Plain, large-scale form language. The cover encircles the ring seat (semi-wrap-over effect).

Pressalit 3000®, incl. BN3 universal hinge

No. 190000-BN3999 with cover
No. 189000-BN3999 without cover

Design/Year

Frogdesign, 1991, registered trade mark

Product Description

PRESSALIT toilet seat with cover, model "3000", art. no. 190 made of colour ingrained duroplast with stainless steel hinges.

- with BN3 universal hinge of stainless steel
- centre distance: 185 - 185 mm
- load - ring seat 240 kg
- suitable for many universal toilets
- 10 year guarantee

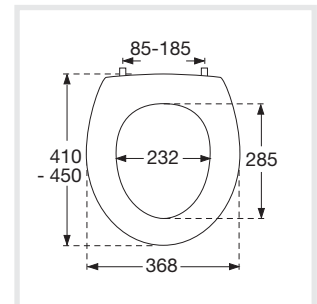

Colour Programme

With cover:
000 white

Without cover:
000 white

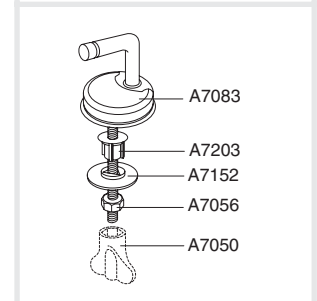

Hinge finish

999 Stainless steel

Spare Parts

A4003 Buffer for pushing into cover, round, white
A4017 Buffer for pushing into seat, long, white
A7220 Distance bush for seat without cover, Chromium plated brass (924)
A7222 Clamp bush for seat without cover, grey
A7236 Clamp bush, grey
A9108 Set of straps and screws, stainless steel

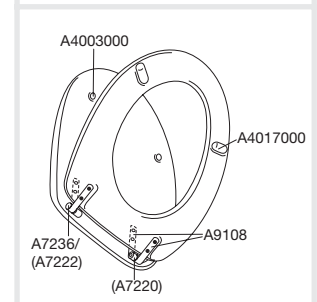

Seats for your senses

<i>Product Weight</i>	Net weight approx. 3,100 kg, incl. hinge		
<i>Packaging</i>	Single carton 5 single cartons in a master carton 18 master cartons (90 seats) per pallet	Dimensions: 449x381x64 mm 456x388x340 mm	Weight: 3,400 kg 17,500 kg
<i>Material Description</i>	<p>TOILET SEAT: The material is colour ingrained duroplast (UF A 10 = urea formaldehyde) that contains no environmentally hazardous substances. UF plastic comprises 67% urea formaldehyde resin, 28% cellulose, as well as 5% minerals, pigments, lubricants and moisture content. The raw material from the supplier contains up to 0.03% free formaldehyde and even less following curing.</p> <p>BUFFERS: EVA (copolymer made of ethylene and vinyl acetate).</p> <p>HINGE LINKS: Stainless steel (V2A) model W. no. 1.4301/M in accordance with DIN 17441/85. Composition: chrome (cr) 17-19%, nickel (ni) 8-11%, carbon <0.05%, molybdenum, manganese, silicone, sulphur, titanium.</p> <p>MOUNT/HINGES: Stainless steel (V2A) model W. no. 1.4301/M in accordance with DIN 17441/85. Composition: chrome (cr) 17-19%, nickel (ni) 8-11%, carbon <0.05%, molybdenum, silicone, sulphur, titanium.</p>		
<i>Suitability List</i>	Usable on universal toilets - see the printed seat suitability specifications		
<i>Cleaning Instructions</i>	Use a mild soap solution. Seat and hinges should not be left damp, but be dried with a soft cloth. When using abrasive, corrosive or chlorine based cleaners for the bowl, avoid contact with seat and hinges. Therefore, when cleaning the bowl, make sure that seat and cover are in an upright position until all the cleaner has been flushed away.		
	<p>The guarantee includes faults or defects in the material of our products within a period of 10 years. Products subject to minor technical modifications and design deviations E. & O.E.</p>		



www.pressalit.com

European Sales Agencies
Unit 10c Tanfield Lea (North) Industrial Estate
Tanfield Lea, Stanley
Co Durham, DH99UU
Tel. 01207 236622, Fax 01207 236633
info@europeansalesagencies.com
www.europeansalesagencies.com

Pressalit A/S
Pressalitvej 1
DK-8680 Ry
Tel. (+45) 8788 8788
Fax (+45) 8788 8789
pressalit@pressalit.com
- a division of Pressalit Group A/S



Seats for your senses