

Orbital Three Curved Quadrant Instruction Manual



Truelife Consumer Guarantee

Please make sure the purchaser/end user completes and returns the Guarantee card which is enclosed with this product or registers on line at www.roman-showers.com/register_guarantee.htm. Failure to validate the Roman Truelife Guarantee will mean only the 1 Year Statutory Guarantee will apply.

PRODUCT CODE REF:

IMPORTANT

- Please ensure the consumer guarantee card enclosed with this product is completed and returned to Roman; please ensure the end user retains this manual.
- Please read these instructions carefully prior to attempting installation.
- Unpack and handle the product with care to avoid damage to the product finish.
- Check for hidden electrical cables and water pipes prior to commencing any drilling work.
- Ensure the walls where the Enclosure is to be fitted are vertical. (If the walls are not completely vertical there is 20mm of adjustment in each wall profile.) **Note:** It is recommended that the walls are tiled after the Tray is fitted and grouted before fitting the Enclosure. This will provide maximum adjustment and will aid sealing.
- No attempt should be made to rework toughened safety glass.
- Pictures used are for illustration purposes **only**, product designs may alter slightly as a result of continuing product development.

Component Check List: Supplied

Ref	Description	Quantities
A	Wall Profiles	2
B	Large Curved Panel	1
C	Small Curved Panel	1
D	Curved Glass Door	1
E	Top Rail	1
F	Bottom Rail	1
G	Infill Trim	2
Fitting Pack		
H	40mm Screws	6
I	Wall Plugs	6
J	Left and Right Top Cap	1
K	16mm Screws	6
L	3mm Drill Bit	1
M	9.5mm Counter Sunk Screws	4
N	Roman Branding Badge	1

Equipment Checklist: Not Supplied

Electric Drill
6mm Masonry Drill Bit
Bathroom Sealant Gun
Bathroom Sealant Tube
Screwdriver
Spirit Level
Tape Measure
Pencil
Wall Plugs (Plasterboard)

Before Assembly and Installation of the Orbital Three Enclosure

- Check to see that you have the correct handing Enclosure for your Tray. This can be done by referring to the label on the side of the product packaging.
- Ensure all parts are in the packaging by checking them against the parts and quantities shown on the component check list above.
- Check the product for defects. Installation queries on damaged parts can not be resolved once the installation has been completed.
- The Tray must be completely sealed along tiled walls, fitted level (check with a Spirit Level) and should have no leaks.

Notes: It is recommended that the Wall Profiles are fitted directly onto tiles or a similar sealed surface. If walls or tray or a combination of both are out of level you will not achieve full adjustment of maximum width. Roman do not stipulate where the British Standard Safety Kite Mark should be positioned on the glass panels when being factory assembled.

Prior to commencing the installation of your Orbital Three Enclosure please ensure that the Enclosure and Tray handing are as per your original requirement (details shown in Stage 22). Once the installation has commenced the installer becomes liable for any rectification costs due to incorrect specification of product at the point of order.

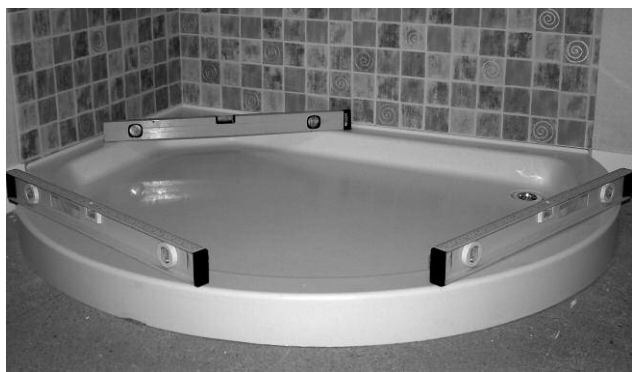

Figure a1

1. Ensure the Tray is completely level, check for any movement in the Tray by standing in it. Fill the Tray with water to check all plumbing for leaks.

Note: Please ensure the Tray is installed as per Manufacturer's Instructions. If the Tray is not completely level this will cause the Curved Glass Door to hang incorrectly during its installation.



Figure a2

2. Once the Tray has been tiled down to and grouted, the Tray should be fully sealed along the tiled walls prior to installation of the Enclosure with a Bathroom Sealant (not supplied). Prior to commencing installation of the Enclosure and once the Bathroom Sealant has cured spray the shower handset around all joints to check for leaks.

Note: It is important that the tiled walls are grouted prior to the installation of the Enclosure. Grout will cause discolouration of the aluminium parts.

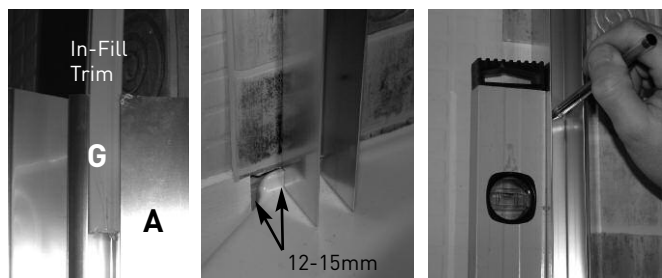

Figure a3

Figure a3i

Figure a3ii

3. Take both Wall Profiles (A) and slide out the In-Fill Trims (F) (Figure a3). Fit both Wall Profiles approx. 12 – 15mm in from the front outside edge of the Tray (Figure a 3i). Ensure both Wall Profiles are completely vertical using a spirit level (the bubble should be in the centre of the two lines). Mark the slots with a pencil where the Wall Profiles are going to be positioned (Figure a 3ii).

Important Note: The above measurement 12 – 15mm has been calculated using a standard tile thickness of 10mm, if using a tile thicker than 10mm you will need recalculate the measurement above i.e. 15mm thick tile you will change to 7 – 10mm.



Figure a4

4. Drill the wall with a 6mm Masonry Drill Bit (not supplied) where the Wall Profiles (A) are to be positioned (Figure a4). Fit the Wall Plugs (I) (if going into a brick or block wall). If going into a plasterboard wall you will need to purchase appropriate wall fixings. Wipe clear all debris from the Tray before referring to the next stage.



Figure a5

Figure a5i

Figure a5ii

5. Where both Wall Profiles (A) are to be positioned onto the Tray, place a bead of Bathroom Sealant (not supplied) the width of the Wall Profile along the tiled wall (Figure a5/a5i). Screw fix the Wall Profiles to the wall with the 40mm Screws (H). Ensure the Wall Profiles remain completely vertical throughout this procedure using a Spirit Level (Figure a5ii).



Figure a6

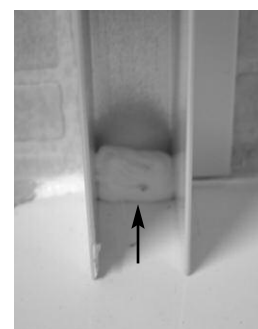

Figure a6i

6. Seal the inside gap between the Tray top and the base of the Wall Profiles (A) with a Bathroom Sealant (not supplied) (Figure a6/a6i).

Note: Failure to carryout this procedure correctly can result in serious water damage and is not covered by the Guarantee.



Figure a7

7. Determine which side of the Tray both Curved Panels are to be situated (**Figure a7**) prior to moving to the next stage.

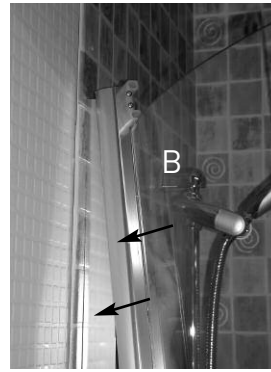

Figure a8



Figure a8i

8. Slide the Large Curved Panel (B) over the top of the required Wall Profile (A) (**Figure a8**). Ensure the Large Curved Panel is positioned over the Wall Profile as shown in **Figure a8i**.

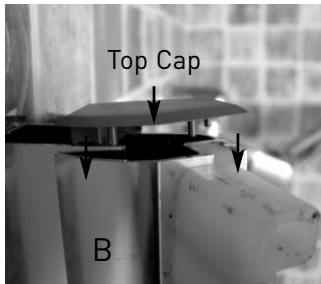

Figure a9

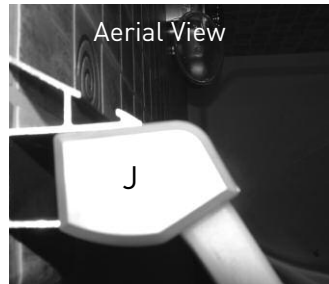

Figure a9i

9. Take the correct handing Top Cap (J) and push fully down into the Large Curved Panel's extrusion (B) (**Figure a9/a9i**). Once the Top Cap is pushed fully down it will stop the Large Curved Panel from moving around within the Wall Profile.

Note: The Top Cap is designed to be a tight fit to restrict movement.

Figure a10

10. Now follow Stages 8 – 9 to fit the Small Curved Panel (C).

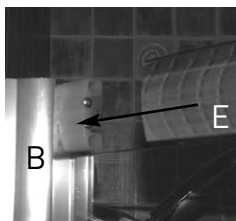

Figure a11



Figure a11i



Figure a11ii

11. Push the Top Rail (E) fully over the top of the Joining Mould attached to the Large Curved Panel (B) then repeat the same process for the Small Curved Panel (C) (**Figure a11**). Please ensure the upper clamps on the Top Rail are located onto the ends of the Glass of both Curved Panels (**Figure a11i**). Once the Top Rail is in position, using the 9.5mm Counter Sunk Screws (M) screw fix the Top Rail through the predrilled holes into the joining moulds (**Figure a11ii**). Ensure all screws are fully tightened.

Note: Ensure the Top Rail is pushed tight up against both Curved Panels.

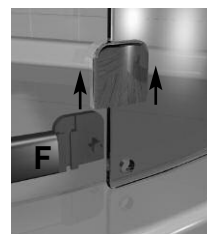

Figure a12

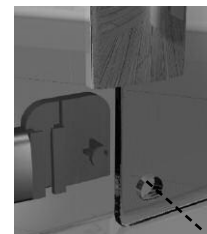

Figure a12i



Figure a12ii

12. Slide the Finishing Moulds off the Bottom Rail (F) (**Figure a12**). Take the Bottom Rail and position both ends into the holes at the bottom of both Curved Panels (**Figure a12i**). Once the Bottom Rail is in position slide the Finishing Moulds down over the top of the Bottom Rail (**Figure a12ii**). To enable you to slide the finishing moulds down over the top of the Bottom Rail you will need to pull the vertical seal slightly off the ends of both Curved Glass Panels.

Note: Once the Bottom Rail is in position please ensure you have an equal gap all around the outside of the Tray .



Figure a13

13. Once you have an equal gap around the outside of the Tray you need to make sure the Curved Panels are completely vertical, position the spirit level onto the leading edge of both Curved Panels (the bubble must be in the centre of the two lines). Move inside the Enclosure and drill through the pre-drilled holes of the Wall Profiles into both Curved Panels with a 3mm drill bit (**Figure a12**).

Note: Please ensure both curved panels are completely vertical.

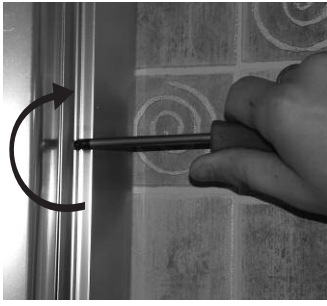

Figure a14

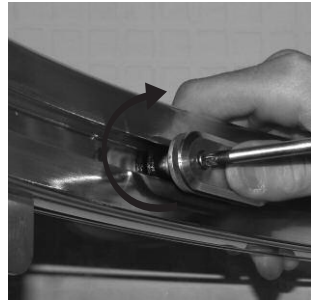

Figure a14i

14. Screw fix the 16mm Screws (K) into the holes that were drilled in **Stage 13** with a Screwdriver (not supplied) (**Figure a14**). Inside the Enclosure take the Screws out of both Wheel Assemblies and remove the Brackets that are situated in the Top Rail (E) (**Figure a14i**). Place the screws and brackets in a safe place as you will require these in **Stage 16**.

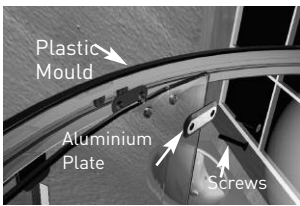

Figure a16

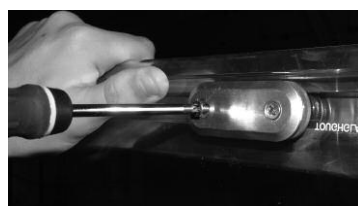

Figure a16i

16. Lift the Curved Glass Door (D) to the required height. Push the Screws which were removed in **Stage 14** through the Aluminium Plate then push the Screws through the two holes in the Curved Glass Door and then into the Plastic Moulding (**Figure a16**). Align the two Screws with the Wheels in the Top Rail (E). Once the Screws are aligned apply pressure on the inside of the Curved Glass Door and to the outside of the Top Rail and fully tighten the two Screws into the Wheels using a Screwdriver (not supplied) (**Figure a16i**). Repeat the same procedure to fit the remaining Wheel Assembly.

Note: To fit the Curved Glass Door you will require the help of an assistant.



Figure a18



Figure a18



Figure a18ii

18. Once the Bottom Rail (F) is over the Door Guide and the Curved Glass Door (C) is lifted over the Static Guide, position both ends of the Bottom Rail into the holes of both Curved Panels (**Figure a18**). Once the Bottom Rail is into position slide the Finishing Moulds back over the top of the Bottom Rail (**Figure a18ii**).

Note: Prior to sliding the finishing moulds down over the top of the Bottom Rail, please follow the sealing process (**Figure A18ii**).

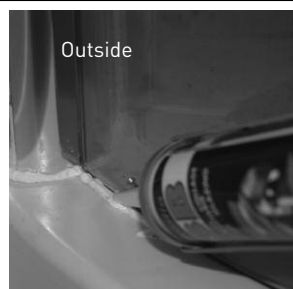

Figure a20



Figure a20i

20. Using a Bathroom Sealant (not supplied) seal both sides of the Wall Profiles (A) vertically to the inside and outside of the Enclosure where they meet the tiles only. (**Figure a20/a20i**). Then fully seal the Enclosure along the Tray top from the outside only (**Figure a20**). Please allow 24 hours for the Bathroom Sealant to cure prior to using the Enclosure.

Note: At no stage should you seal the Enclosure along the Tray top on the inside as this is a self draining unit. Failure to comply will result in the Enclosure leaking and is not covered by the Guarantee.

15. Remove the Bottom Rail (F) that was installed in **Stage 12**, this can be done by reversing the procedure in **Stage 12**.



Figure a17



Figure a17i

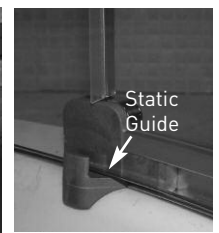

Figure a17ii

17. Take the Bottom Rail (F) and position over the top of the Door Guide that is already fixed to the bottom of the Curved Glass Door (C) (**Figure a17**). Please ensure that the Bottom Rail is located correctly over the Door Guide (**Figure a17ii**).

Note: Please ensure the Curved Glass Door is located into the Static Guide correctly (**Figure a17ii**), to achieve this lift the Curved Glass Door over the top of the Static Guide



Figure a19

19. Once completely satisfied with your installation push fit the Infill Trim (G) into the vertical grooves of both Wall Profiles (A) (**Figure a19**). This will cover the Screws that were screw fixed in **Stage 14**.

Tip: Push the thin end into the vertical groove first.

Note: The Infill Trim is designed to be a tight fit.

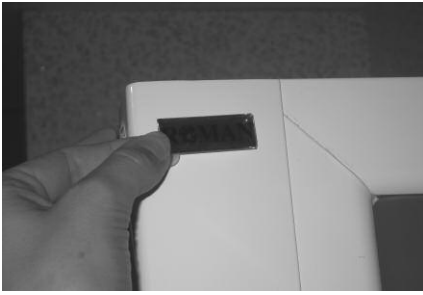
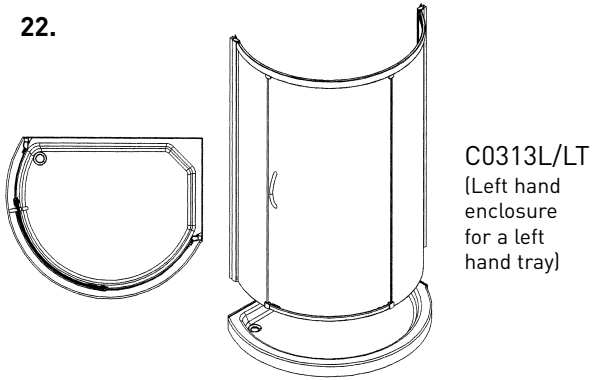

Figure a21

Figure a21

21. Ensure the Roman Branding Badge (N) is positioned on a non moving aluminium part to complete your installation.

22.



C0313L/LT
(Left hand enclosure for a left hand tray)

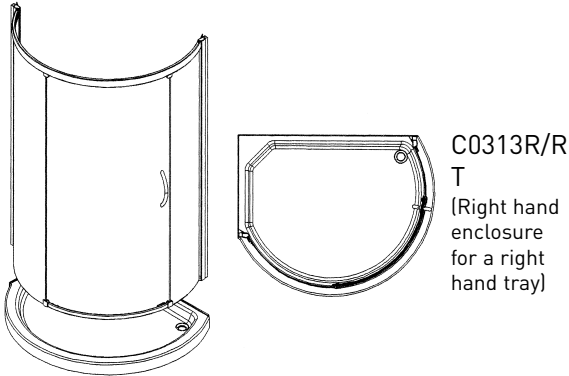

C0313R/R
T
(Right hand enclosure for a right hand tray)

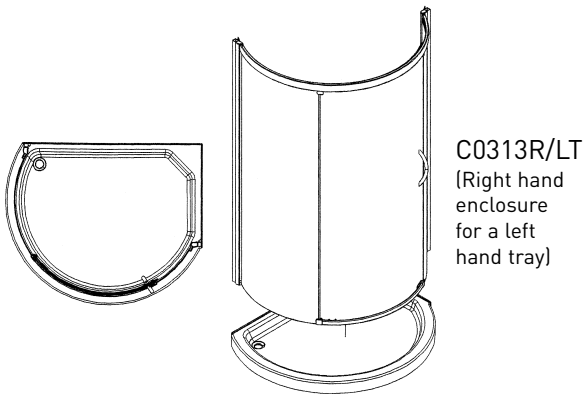

C0313R/LT
(Right hand enclosure for a left hand tray)

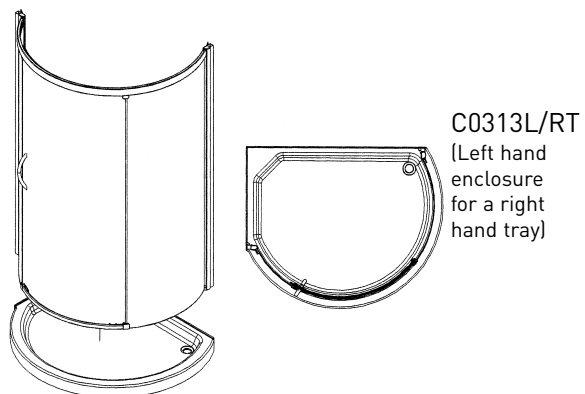

C0313L/RT
(Left hand enclosure for a right hand tray)

Outside View of C0313 L/LT

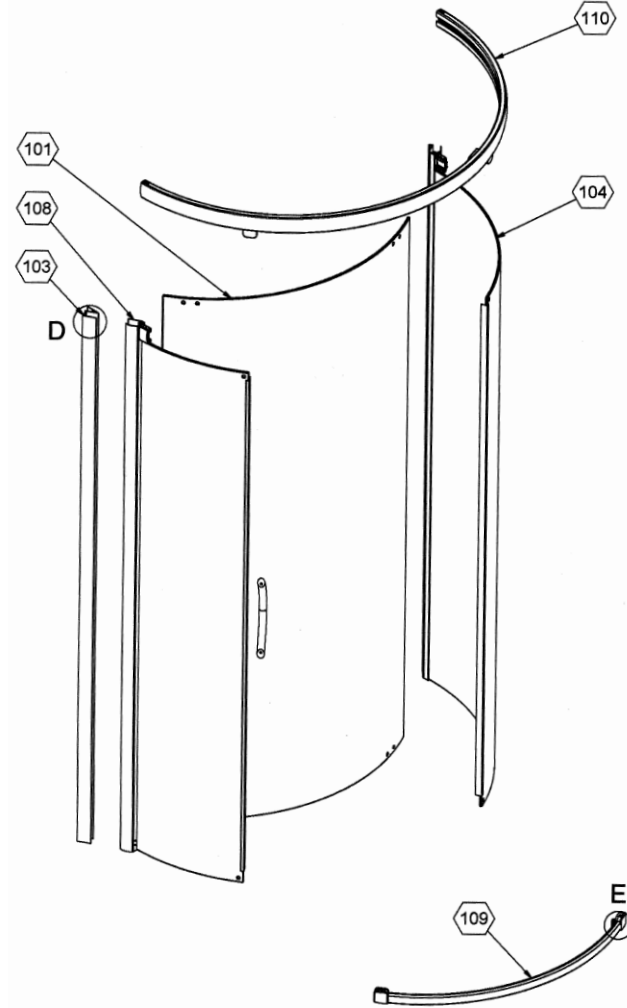

Ref	Description	Pic Ref
A	Wall Profiles	No 103
B	Large Curved Panel	No 104
C	Small Curved Panel	No 108
D	Curved Glass Door	No 101
E	Top Rail	No 110
F	Bottom Rail	No 109
G	In-Fill Trim	

Orbital Three Quadrant Enclosure Trouble Shooter Guide

Problem		Solution
Leaking	①	Check that the inside gap between the Tray and Wall Profiles has been sealed correctly (Figure a6/a6i) .
	②	Ensure the Tray is fully sealed along the tiled walls prior to installation (Figure a2)
	③	If the inside joint between the Enclosure and The Tray top is sealed, this will cause leakage – the sealant must be removed.
	④	Ensure the Wall Profiles on the tiled walls are sealed both vertically inside and outside (Figure a20/a20i) .
	⑤	Ensure the outside joint between the Enclosure and Tray top is fully sealed (Figure a20) .
	⑥	Ensure the Bottom Rail was sealed correctly before sliding the finishing moulds on (Figure a18ii) .
Enclosure alignment on Tray	①	Is the Enclosure fitted onto a tiled wall?
	②	Are the Wall Profiles fitted approx. 12-15mm from the front outside edge of the Tray?
	③	Are the Wall Profiles completely vertical?
Door not running smoothly	①	Ensure both Wall Profiles are completely vertical.
	②	Ensure the Tray is completely level.
	③	Please ensure the enclosure has an equal gap around the Tray Stages 12 and 13 .
Door alignment	①	Ensure both Wall Profiles are completely vertical.
	②	Ensure the Tray is completely level.
	③	If the door is not aligned correctly, you have some adjustment in both Wheel Assemblies.

Should you experience any problems during installation please refer to your Instruction Manual Trouble Shooter Guide or alternatively please contact Roman Customer Services on:
01325 328034.

To enable Customer Services to provide you with an excellent level of service it is important that you quote your Product Code and Reference Number - these numbers can be found on the front of your Instruction Manual

Maintaining Your Enclosure

DO NOT use acidic based descaler products or products which are unsuitable for cleaning enamel surfaces, including abrasive cleaners or cleaners containing bleach or solvents, as these products will affect both the anodised and coated framework.

NEVER use scouring powder or pads or sharp instruments when cleaning the enclosure.

Roman Shower Enclosures and Bath Screens are designed for luxury showering and with care and attention you can keep them looking new for longer by using the strongly recommended **Roman Ultra Care**, the multi-purpose glass protector after cleaning. Alternatively, occasionally wipe your Roman Shower Enclosure with a mild detergent diluted with water and polish with a soft cloth. If you live in a hard water area, periodically clean with a 50/50 solution of white vinegar and soak for five minutes and remove any limescale residue by rinsing with warm water. Periodically clean the seals of your Enclosure with an anti-bacterial spray. This is all you require to keep the glass, seals and coated / anodised aluminium parts looking new.

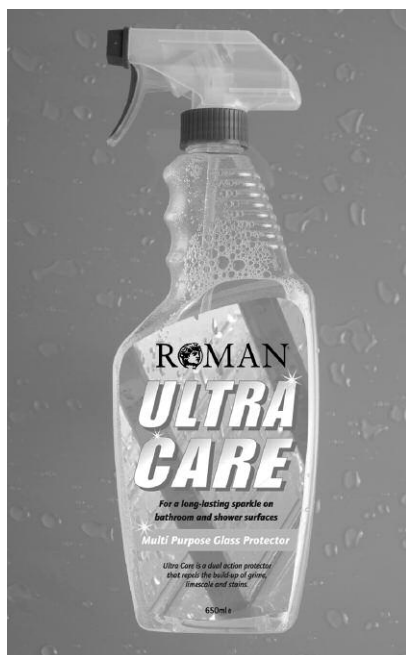

Ultra Care

THE MORE YOU SPRAY – THE MORE YOU PROTECT.

Roman Ultra Care is a product from Roman designed to give all your shower and bathroom surfaces a long-lasting sparkle. The benefit of Ultra Care is the more you spray, the more you protect.

Ultra Care is a multi-purpose glass protector that repels the build-up of grime, limescale and stains.

Roman Ultra Care was developed for Roman shower enclosures and screens but is a unique and effective non-filming formula for all glass surfaces, tiles, shower seals and aluminium frames, taps, trays and baths.

Why not try it on your car windscreen!

For your nearest stockist please call +44 (0) 1325 328034

ROMAN LIMITED, WHITWORTH AVENUE, AYCLIFFE INDUSTRIAL PARK, COUNTY DURHAM, DL5 6YN, ENGLAND, UK.

Member of



GENERAL RECEPTION: PHONE +44 (0) 1325 311318 FAX +44 (0) 1325 319889

CUSTOMER SERVICES: PHONE +44 (0) 1325 328034 FAX +44 (0) 1325 328031

SALES ENQUIRIES: PHONE +44 (0) 1325 328033 FAX +44 (0) 1325 328027

www.roman-showers.com